



DUGGAN PROFILES & STEEL SERVICE CENTRE Ltd

Tel: 056 772 2485 Fax: 056 776 3411
www.steel.ie

Order No. _____

Reference _____ Page _____ of _____

Customer contact _____ Date reqd. _____

Site contact _____ Deliver to _____

Pick No. _____
(Office use)

Cleats

- The section depth the cleat is to suit
- Tick (✓) if Bolt-on is required.
- Tick (✓) if Weld-on is required.
- Tick (✓) to select optional stiffener.
- Length of extended cleats, leave blank for standard cleats
- Tick (✓) if unprimed bolt-on are required, otherwise leave blank

Qty	¹ Section Depth	² Bolt-on	³ Weld-on	⁴ Stiffened	⁵ Length	⁶ Unprimed
		<input type="checkbox"/>	<input type="checkbox"/>	<input type="checkbox"/>		<input type="checkbox"/>
		<input type="checkbox"/>	<input type="checkbox"/>	<input type="checkbox"/>		<input type="checkbox"/>
		<input type="checkbox"/>	<input type="checkbox"/>	<input type="checkbox"/>		<input type="checkbox"/>
		<input type="checkbox"/>	<input type="checkbox"/>	<input type="checkbox"/>		<input type="checkbox"/>
		<input type="checkbox"/>	<input type="checkbox"/>	<input type="checkbox"/>		<input type="checkbox"/>
		<input type="checkbox"/>	<input type="checkbox"/>	<input type="checkbox"/>		<input type="checkbox"/>

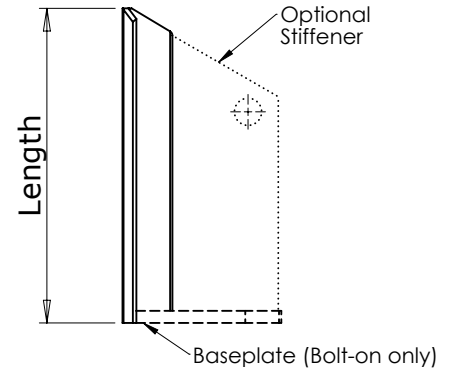

Sleeves

- Tick (✓) if Sigma Sleeve is required.
- Tick (✓) if Cee Sleeve is required.
- The section depth the sleeve is to suit
- Tick (✓) for galvanised sleeves.
- Tick (✓) for prepainted sleeves.

Qty	¹ Sigma	² Cee	³ Section Depth to suit	⁴ Galvanised	⁵ Prepainted
	<input type="checkbox"/>	<input type="checkbox"/>		<input type="checkbox"/>	<input type="checkbox"/>
	<input type="checkbox"/>	<input type="checkbox"/>		<input type="checkbox"/>	<input type="checkbox"/>
	<input type="checkbox"/>	<input type="checkbox"/>		<input type="checkbox"/>	<input type="checkbox"/>
	<input type="checkbox"/>	<input type="checkbox"/>		<input type="checkbox"/>	<input type="checkbox"/>

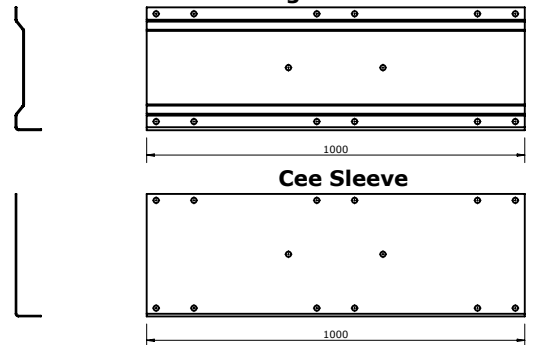

Apex Ties

Qty	Length	Angle A	Angle B

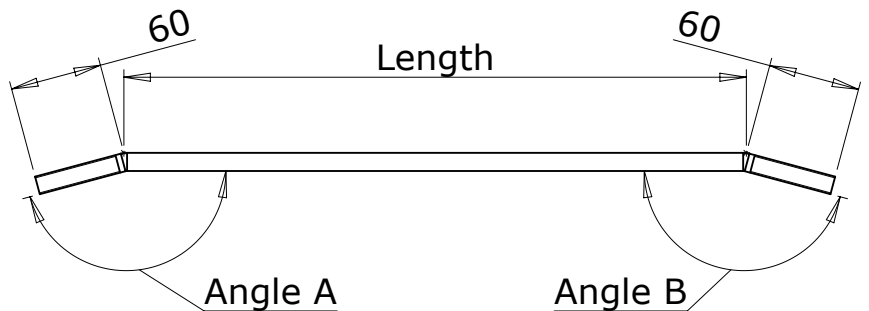

Stays

Qty	Length	ID Mark

