



Order No. _____

Date reqd. _____

Reference _____

Customer contact _____

Page _____ of _____

Site contact _____

Deliver to _____

Material/Colour
(1 colour only per page) _____

Tick (✓)

Thickness 0.5 0.55 0.6 0.7

Tick (✓)
Profarm

Proclad

Procolor

Tick (✓)
1000/32

800/32*

*800/32 profile available
in Profarm only

i Instructions for Detailer

- 1) Select the required Colour, thickness and profile type.
- 2) Fill in the dimensions, angles and radius on the relevant profile along with the quantity of each hand required and the overall sheet length.

Handing of sheets

The required direction of lay must be specified when ordering as cranked sheets with uneven leg lengths can be laid in one direction only. Select from the options shown below.

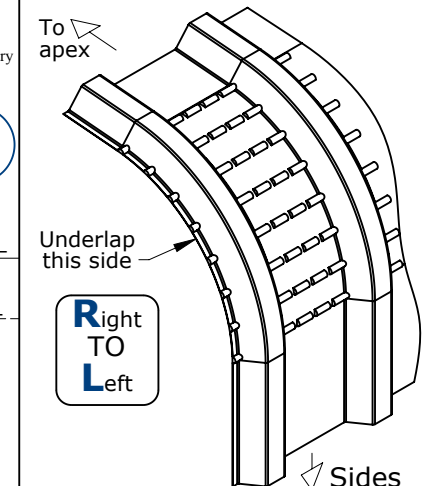
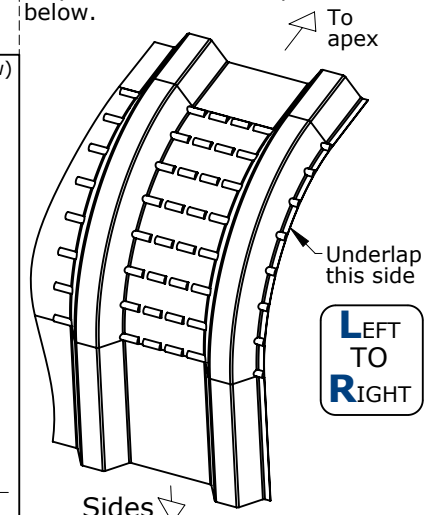

CRANKED RIDGE (Fill in details below)

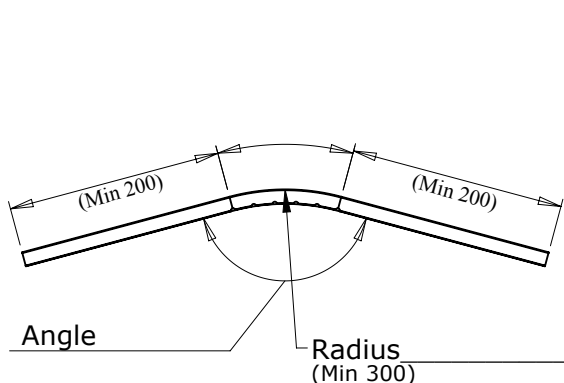

CRANKED EAVES (Fill in details below)

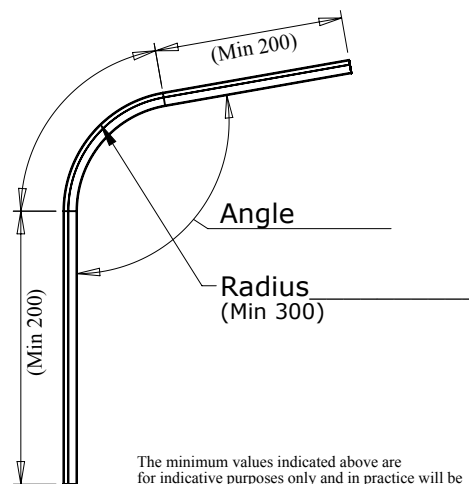

The minimum values indicated above are for indicative purposes only and in practice will be determined by factors such as sheet length, geometry and material thickness. Check with us before detailing/ordering for job specific information

CRANKED MONORIDGE (Fill in details below)

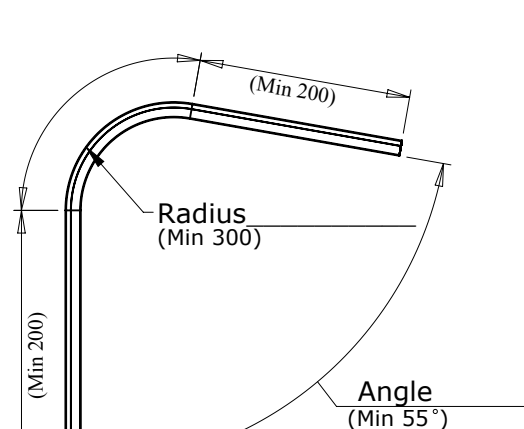

The minimum values indicated above are for indicative purposes only and in practice will be determined by factors such as sheet length, geometry and material thickness. Check with us before detailing/ordering for job specific information

Custom Sizes
(Enter details below)

Line No.
(Office use) _____

Qty
(L TO R) _____

Qty
(R TO L) _____

Sheet Length

(Office use)

Crimps _____ @ _____ °
(Qty) (Degrees)

Spacings _____ @ _____ mm
(Qty) (Spacing)

Custom Sizes
(Enter details below)

Line No.
(Office use) _____

Qty
(L TO R) _____

Qty
(R TO L) _____

Sheet Length

(Office use)

Crimps _____ @ _____ °
(Qty) (Degrees)

Spacings _____ @ _____ mm
(Qty) (Spacing)

Custom Sizes
(Enter details below)

Line No.
(Office use) _____

Qty
(L TO R) _____

Qty
(R TO L) _____

Sheet Length

(Office use)

Crimps _____ @ _____ °
(Qty) (Degrees)

Spacings _____ @ _____ mm
(Qty) (Spacing)