

DUGGAN



DUGGAN PROFILES & STEEL SERVICE CENTRE Ltd.



QUALITY
ISO 9001:2008
NSAI Certified

Issue 3 - April 2015

THE COMPLETE RANGE OF **GRANT ACCEPTED** AND GENERAL ROOFING PRODUCTS FOR THE AGRICULTURAL SECTOR

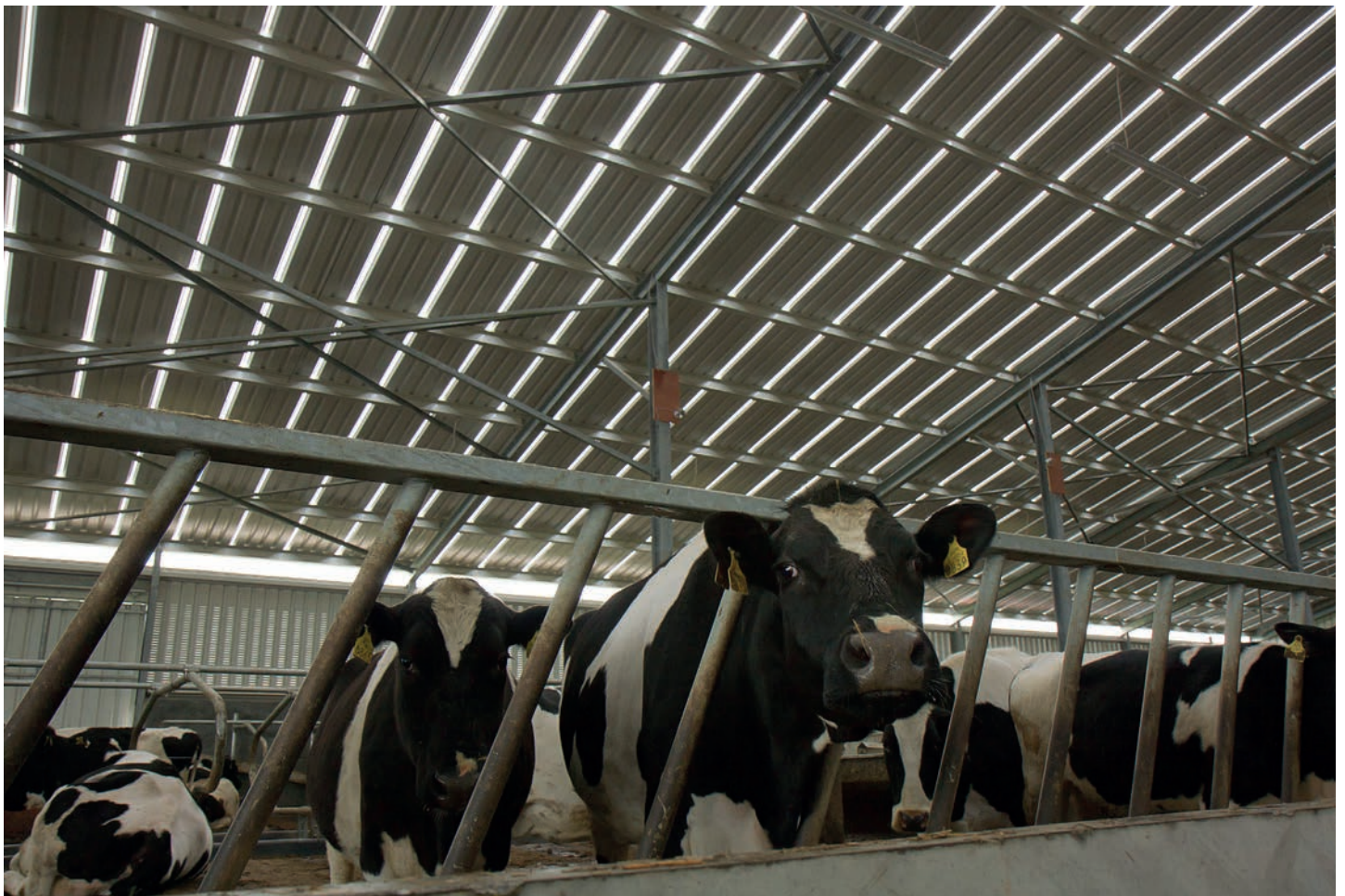



<i>Table of Contents</i>	3
--------------------------	---

GRANT ACCEPTED RANGE

<i>10/3 or 14/3 Corrifarm®</i>	4 - 5
<i>1000/32 & 800/32 Profarm®</i>	6 - 7
<i>1000/32 Proair® System</i>	8 - 9
<i>Agrilight®</i>	10 - 11
<i>Complete Profarm® Building</i>	12 - 13
<i>ProSigma+® Purlins</i>	14 - 15
<i>ProSigma+® Purlins Load Tables</i>	16 - 17



*For Terms & Conditions:
See website at www.steel.ie*

GENERAL PRODUCT RANGE

<i>14/3 Corricolor®</i>	18
<i>1000/32 Procolor®</i>	19
<i>10/3 Corrigalv®</i>	20
<i>8/3 GALV Corrugated</i>	21
<i>Protherm-40</i>	22 - 23
<i>NonDrip™</i>	24
<i>Gutters, Downpipes & Accessories</i>	25
<i>Trims & Flashings</i>	26
<i>Orderforms</i>	27

Figures and comments given in this brochure are given for guidance purposes only. While care has been taken to ensure accuracy Duggan Profiles & Steel Service Centre Ltd. and its related companies do not accept liability for errors / or omissions. Customers should satisfy themselves of the suitability of the products supplied or manufactured by Duggan Profiles & Steel Service Centre Ltd. for the use intended.



CORRIFARM[®] 10/3 PROFILES:

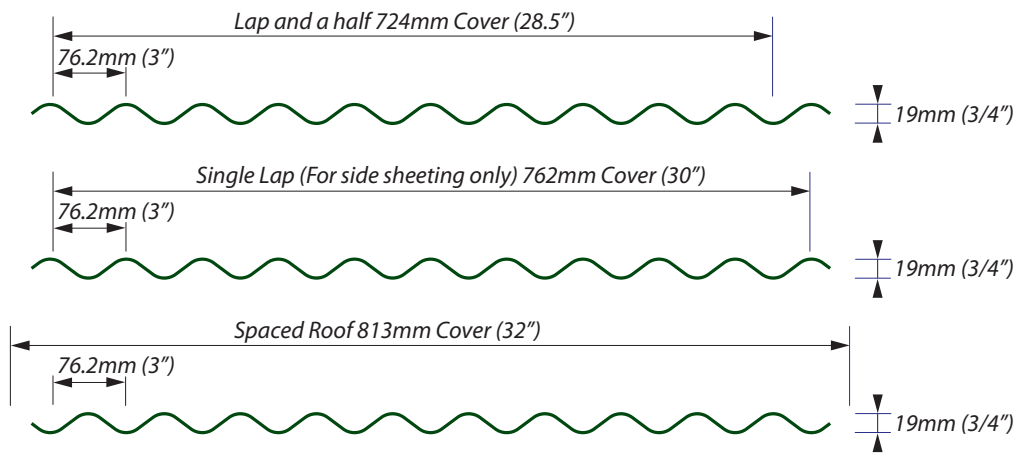

CORRIFARM[®] 14/3 PROFILES: (Not recommended for spaced roofing)

Please Note: Lap minimum recommendation for roofs is One and a Half Lap or Double Lap

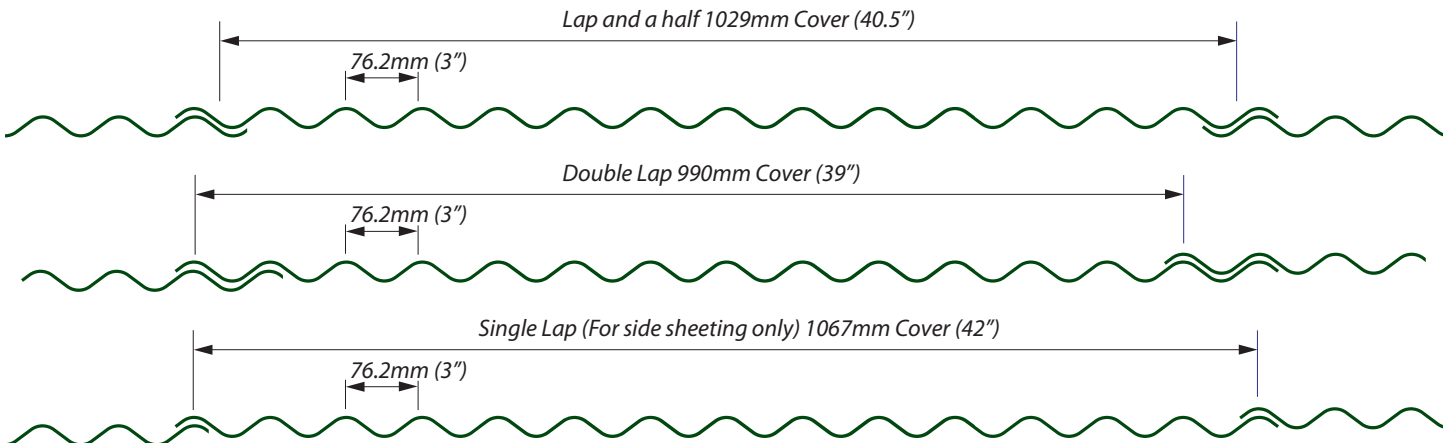

Quality:

Corrifarm® is a premium quality product manufactured to EN 10142: 1991. It consists of a DX51D+Z275 commercial quality steel substrate galvanised to 275 grammes per square metre. The outer surface is then treated, primed and coated with 25 microns of Slate Grey, Juniper Green or Turf Brown high grade polyester.

Internal Environment:

The inner surface is treated, primed and coated with 35 microns of high grade polyester, specifically developed to cope with the aggressive environment experienced in livestock housing.

Corrifarm® has a bright undercoat which gives a light, airy atmosphere particularly effective in conjunction with Agri-light®.

Stock:

Corrifarm® is available in 0.55mm and in 0.70mm in stock lengths 6', 7', 8', 9', 10', 11', 12' or specific lengths made to order.

Grant Acceptance:

Corrifarm® is accepted by the Department of Agriculture, Fisheries and Food for use in high humidity Livestock Housing. Corrifarm® conforms to the Department's "Performance Specifications for Pre-painted sheeting for animal housing". Please consult your Farm Development Service office for specific instructions relating to appropriate use.



Manufacture:

Corrifarm® is manufactured by Duggan Profiles & Steel Service Centre Ltd., a Duggan Steel Group company which is committed to total quality products.

With management experience in serving the farming and business communities extending over forty years, D.P. & S.S.C. is confident of its ability to serve your requirements no matter how specific they may be.

Storage & Handling:

Corrifarm® must not be stored outside. Water ingress between sheets will have a negative effect on the performance of the sheet. Wrapping is only a temporary protection for transport purposes.

For advice on storage and handling please consult the leaflet enclosed in each bale of Corrifarm®.

Distribution:

Corrifarm® is available countrywide through our long established customer base of approved merchants, stockholders, manufacturers and erectors.

Should you have any trouble locating your nearest supplier please contact our office.

Accessories:

Duggan Profiles & Steel Service Centre provides a full range of complementary services and products for its sheeting range including cocktailing and curving facilities, gutters, trims, flashings, fittings and roof lights.

Guaranteed Irish:

Corrifarm® is a guaranteed Irish product.

Guaranteed Long Life:

Corrifarm® is guaranteed for 15 years.

For Terms & Conditions: see our website at www.steel.ie

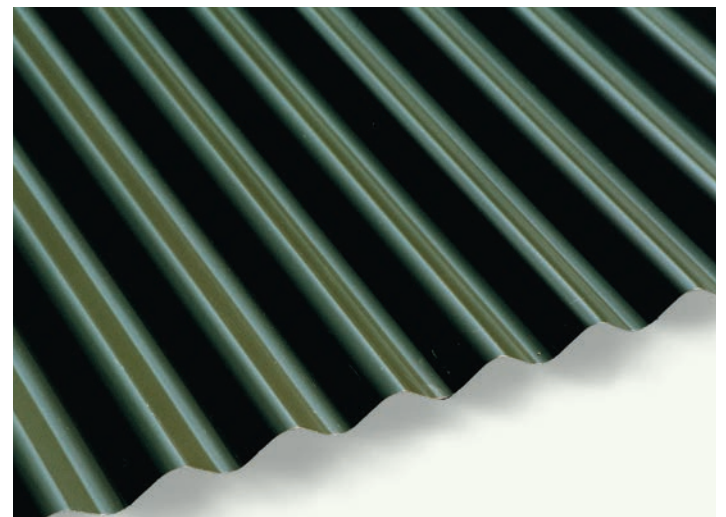

**GRANT
ACCEPTED**

For Terms & Conditions:
See website at www.steel.ie

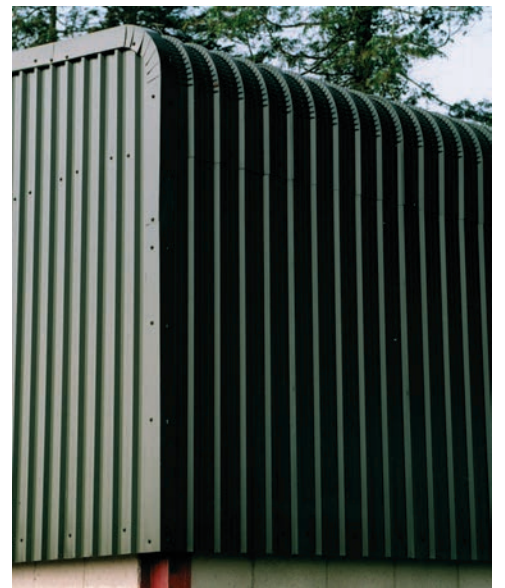

Quality:

Profarm® is a premium quality product manufactured to EN 10142: 1991. It consists of a DX51D+Z275 commercial quality steel substrate galvanised to 275 grammes per square metre. The outer surface is then treated, primed and coated with 25 microns of Slate Grey, Juniper Green or Turf Brown high grade polyester.

Internal Environment:

The inner surface is treated, primed and coated with 35 microns of high grade polyester, specifically developed to cope with the aggressive environment experienced in livestock housing. Profarm® has a bright coloured undercoat which gives a light, airy atmosphere particularly important for good working conditions, particularly effective in conjunction with Agrilight®.

Stock:

Profarm® is available in 0.55mm in 1000mm cover width and in 0.55mm and 0.70mm in 800mm cover width.

Grant Acceptance:

Profarm® is accepted by the Department of Agriculture, Fisheries and Food for use in high humidity Livestock Housing. Profarm® conforms to the Department's "Performance Specifications for Pre-painted sheeting for animal housing". Please consult your Farm Development Service office for specific instructions relating to appropriate use.

Profile:

Profarm® is manufactured in a 32mm profile in a 1000mm cover width for enclosed roofs or in 800mm cover width for spaced roofs. Profarm® is roll-formed with mini-ribs, unless otherwise requested.

Manufacture:

Profarm® is manufactured by Duggan Profiles & Steel Service Centre Ltd., a Duggan Steel Group company committed to total quality products. With management experience in serving the farming and business communities extending over forty years, D.P. & S.S.C. is confident of its ability to serve your requirements no matter how specific they may be.

Storage & Handling:

Profarm® must not be stored outside. Water ingress between sheets will have a negative effect on the performance of the sheet. Wrapping is only a temporary protection for transport purposes. For advice on storage and handling please consult the leaflet enclosed in each bale of Profarm®.

Distribution:

Profarm® is available countrywide through our long established customer base of approved merchants, stockholders, manufacturers and erectors. Should you have any trouble locating your nearest supplier please contact our offices or one of the Duggan Steel depots.

Accessories:

Duggan Profiles & Steel Service Centre provides a full range of complementary services and products for the sheeting range including cocktailing and curving facilities, gutters, trims, flashings, fittings and roof lights.

Guaranteed Irish:

Profarm® is a guaranteed Irish product.

Guaranteed Long Life:

Profarm® is guaranteed for 15 years. For Terms & Conditions: see our website at www.steel.ie

PROFARM® 800/32 AND 1000/32 PROFILE

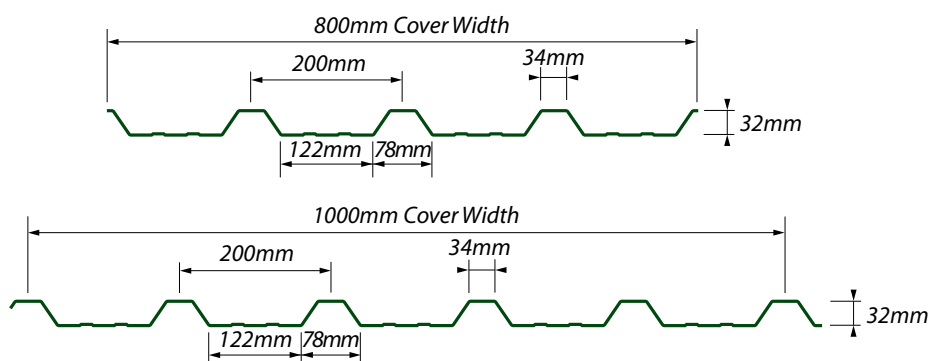



For Terms & Conditions:
See website at www.steel.ie

**GRANT
ACCEPTED**

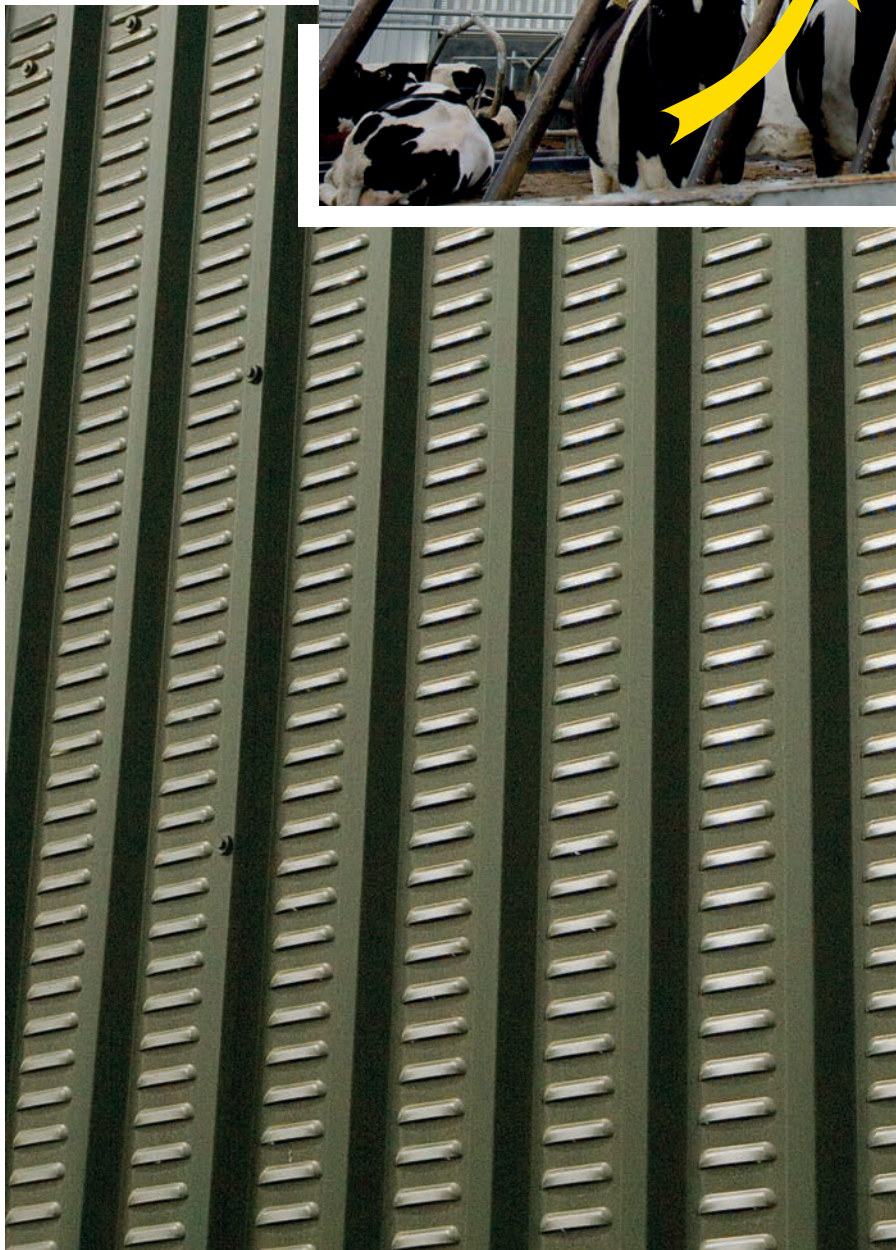

The Proair[®] System:

- Spaced Roof Sheet,
- Ventilated Side Sheet,
- Cranked Ridges.

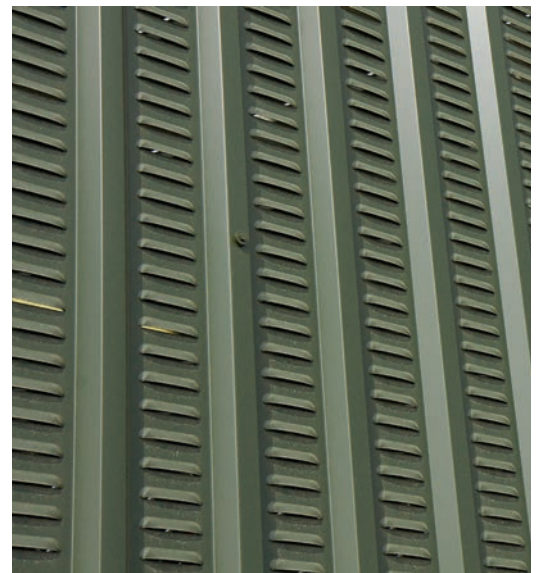

The Proair[®] System is produced from the following three components:

- 1) Spaced Roof Sheet,
- 2) Ventilated Side Sheet,
- 3) Cranked Ridges.

1) Spaced Roof Sheet:

800/32 Proair[®] spaced Roof Sheet is designed to give maximum rigidity to the unsupported section of the material which is subject to damage in other methods of spacing. It is also the most aesthetically appealing of any of the spaced roof sheets available in Ireland.

2) Ventilated Side Sheet:

Proair[®] is provided in 32 mm box profile in 800mm spaced side sheet or 1000mm lapped side sheet. For maximum ventilation we recommend 800 / 32 which yields up to 30% air-flow as shown in wind tunnel tests performed in Ireland by the Dublin Institute of Technology, Bolton street. At 30% air-flow Proair[®] provides 3 to 4 times more ventilation than other sheets on the market today.

When specifying ventilated side sheeting ask for Proair[®] sheets:

Maximum ventilation at no extra cost!

3) Cranked Ridge:

1000/32 Profarm[®] is used to produce the cranked raised ridge. No spacing is applied to the cranked ridge.

Stock:

Proair[®] is available in 0.55mm in 1000mm cover width and in 0.55mm and 0.70mm in 800mm cover width.

Manufacture:

Proair[®] is manufactured to your specific length requirements. Proair[®] is available from Duggan Profiles & Steel Service Centre Ltd., a Duggan Steel Group company, to complement our Profarm[®] product to provide the Agri Sector with more choice in ventilation of animal houses.

Storage & Handling:

Proair[®] must not be stored outside. Water ingress between sheets will have a negative effect on the performance of the sheet. Wrapping is only a temporary protection for transport purposes.

For advice on storage and handling please consult the leaflet enclosed in each bale of Proair[®].

Distribution:

Proair[®] is available countrywide through our long established customer base of approved merchants, stockholders, manufacturers and erectors. Should you have any trouble locating your nearest supplier please contact our offices or one of the Duggan Steel depots.

Accessories:

Duggan Profiles & Steel Service Centre provides a full range of complementary services and products for the sheeting range including cocktailing and curving facilities, gutters, trims, flashings, fittings and roof lights.

Guaranteed Irish:

Proair[®] is a guaranteed Irish product.

Guaranteed Long Life:

Proair[®] is guaranteed for 15 years.

For Terms & Conditions: see our website at www.steel.ie

PROAIR 800/32 AND 1000/32 PROFILE:

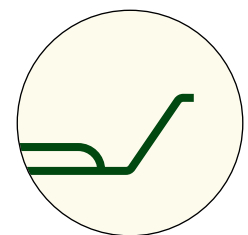
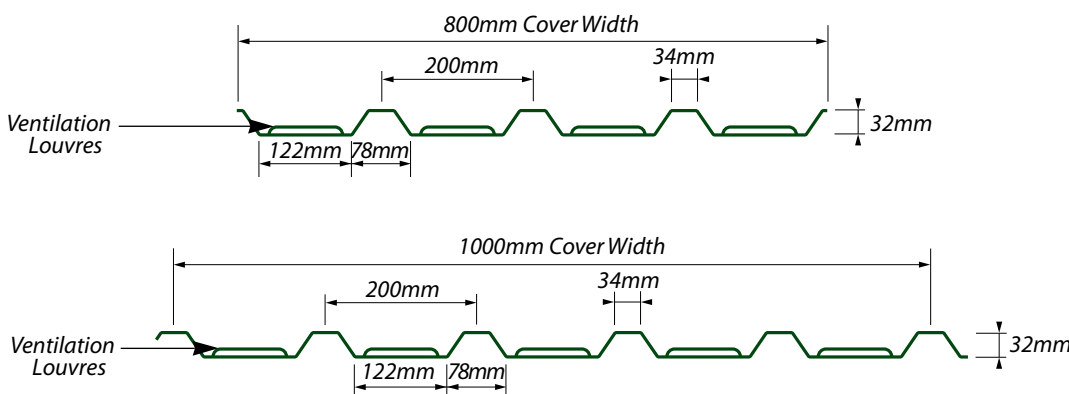

Maximum Rigidity of the un-supported section of spaced roof sheeting

Agrilight® Corrugated Polycarbonate sheet (MarlonCS Longlife) is a high performance rooflight sheet, which admits natural light into agricultural, commercial, industrial, domestic and other buildings.

Agrilight® (MarlonCS Longlife) is manufactured by Brett Martin to suit the exact shape of Duggan Profiles & Steel Service Centre Corrifarm® metal and painted corrugated sheets. The products are suitable for all types of construction; in "New Build" as well as refurbishment and renovation, where they replace PVC and GRP. Agrilight® has a wide field of use not only in the agricultural building sector but also in applications such as swimming pool covers, stadium roofing, wall glazing, etc.

Agrilight® can be used in conjunction with D.P. & S.S.C. Corrifarm® range of profiled building sheet materials or as 'stand alone' glazing in, for example, greenhouses and DIY applications.



Stock sheets

Corrugated profiled sheet in 1.3mm thick is available from stock to match our Corrugated range of steel sheeting (Corrifarm®, Corrigalv® and Corricolor®). Other profiles and thicknesses are also available on order, please contact our sales Department.

UV resistance

A protective co-extruded layer on the outer surface of the sheet forms a barrier which is resistant to the detrimental effects of UV light, minimising long term yellowing and maintaining mechanical properties.

The protected surface is always clearly identified. **The sheet must always be fitted with the UV protected side out**, otherwise it will deteriorate, as will be shown by yellowing and decline of physical properties, eg. the sheet will become brittle and lose impact resistance.

Impact resistance

Agrilight® is a very durable material, many times tougher than glass, with excellent light transmission, fire performance and stability in extreme temperatures. Of all glazing materials polycarbonate exhibits greatest resistance to impact over a temperature range of -40 to +130 °C. It is approximately 200 times more resistant to impact than glass; PVC has limited impact resistance at low temperatures; GRP sheet is resistant to impact but will show impact abrasions much more easily than Polycarbonate. High impact resistance means that Agrilight® is suitable for use in areas where hail storms would cause excessive damage to other glazing materials.

Workability

Agrilight® can be cut or drilled using standard power tools.

Weatherability

Accelerated weathering tests in a weatherometer produce little change in light transmission or yellowness index. Significantly, accelerated and natural weathering have negligible influence on the physical properties of Agrilight®, eg. tensile strength, impact resistance. During the life of the sheet natural weathering will leave its thermal or mechanical properties essentially unaltered.

Fire Performance

Agrilight® exhibits excellent fire performance and in the event of a fire it will soften and open, allowing smoke, heat and gases produced by the fire to escape. This 'venting' property means that damage within buildings can be limited. For details of fire ratings please contact our technical department.

AGRILIGHT 10/3 PROFILE:

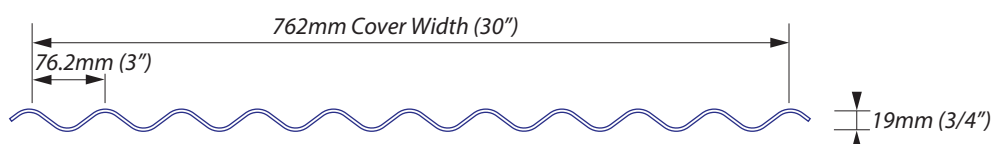

Chemical Resistance

Agrilight® has in general excellent resistance to most chemicals; resistance to specific compounds depends on concentration and temperature, duration of exposure and stress within the sheet. Contact with plastic coated metal sheets, wet wood preservatives, solvents and alkali cleaners should be avoided.

Condensation

Condensation will form on the underside of a roof made from any thin sheeting material. To minimise condensation within an enclosed structure, sources of moisture should be minimised and good ventilation should be provided.

Guarantees

Agrilight®, is manufactured under Quality Management Systems registered to BS EN ISO 9001:2000 by Brett Martin as MarlonCS Longlife. The sheet carries a 10 year Guarantee in respect of light transmission and a 3 year Guarantee in respect of weather breakage.

Isolation from plastisol coating

Plastisol coating on roofing sheets is aggressive to polycarbonate. It is essential that the lapped area of metal sheet at either side of and at the lower end of the polycarbonate roof-light has an aluminium foil adhesive tape applied to completely isolate the polycarbonate from the plastisol-coated metal.

Installation Guidelines

When installing any roofing material, including rooflights, ensure that safe working methods are adopted and appropriate safety equipment is used.

- Sealants and tapes must be compatible with polycarbonate.
- All accessory materials should be light coloured, preferably white.
- Sheets which spans up to two purlin spacings are of optimum length to cope with thermal movement.
- Maximum recommended sheet length for Agrilight® is 4m.

For detailed information on Agrilight® 10/3, 14/3 roofing profile installation specification for 10 year Class B Non-Fragility Period, please refer to our website at:

<http://steel.ie/Profiles/AgrilightFixingInst.html>

Prolight® is also available to suit Profarm® Box Profile.

Prolight® (MarlonCS Longlife) is manufactured by Brett Martin to suit the exact shape of Duggan Profiles & Steel Service Centre 1000/32 Profarm® metal and painted profiles.

The products are suitable for all types of construction; in "New Build" as well as refurbishment and renovation, where they replace PVC and GRP.

→ The complete **Grant Accepted** solution for

Crank

Profar

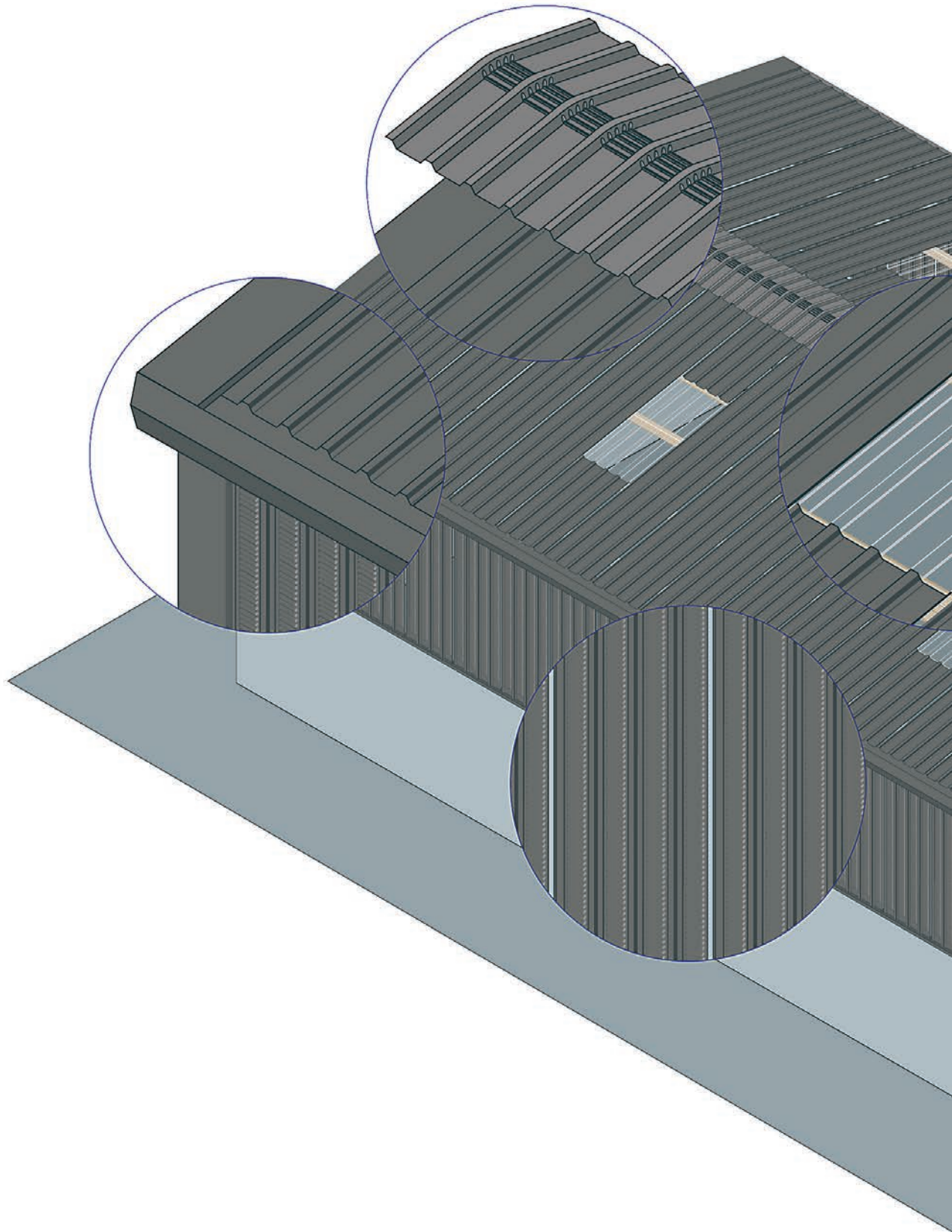

with complete weather protection

your farm building with a **15 year Guarantee!**

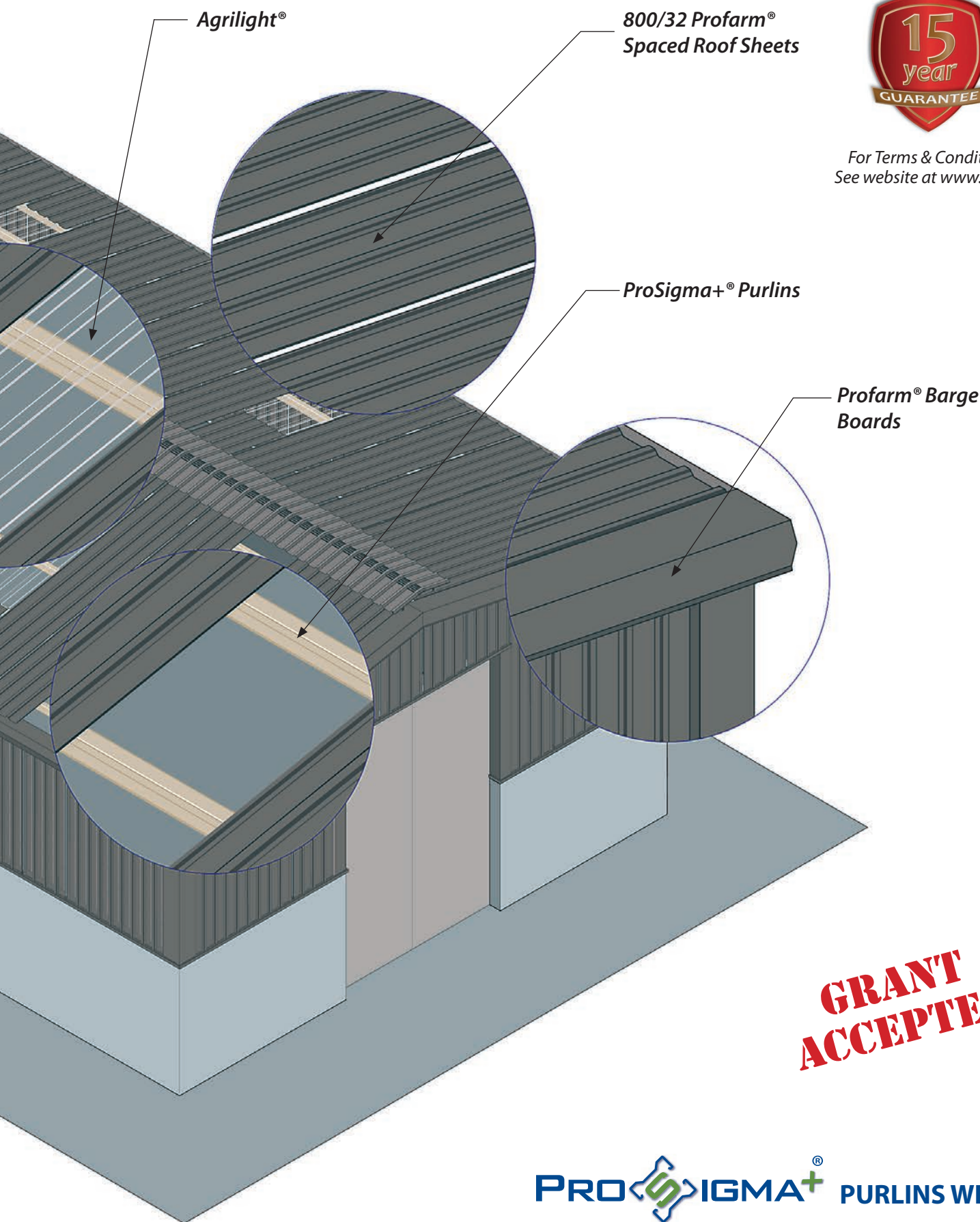

For Terms & Conditions:
See website at www.steel.ie

**GRANT
ACCEPTED**

PRO SIGMA+[®] PURLINS WITH
PRO AIR[®] SYSTEM



PRO SIGMA⁺
GOLD-ROLLED STEEL
PURLIN & RAIL
SYSTEM

For Terms & Conditions:
See website at www.steel.ie

Prepainted Purlins, Rails, Eaves Beams and Cee sections from the Duggan Profiles ProSigma+ range are manufactured from organically coated structural steel:

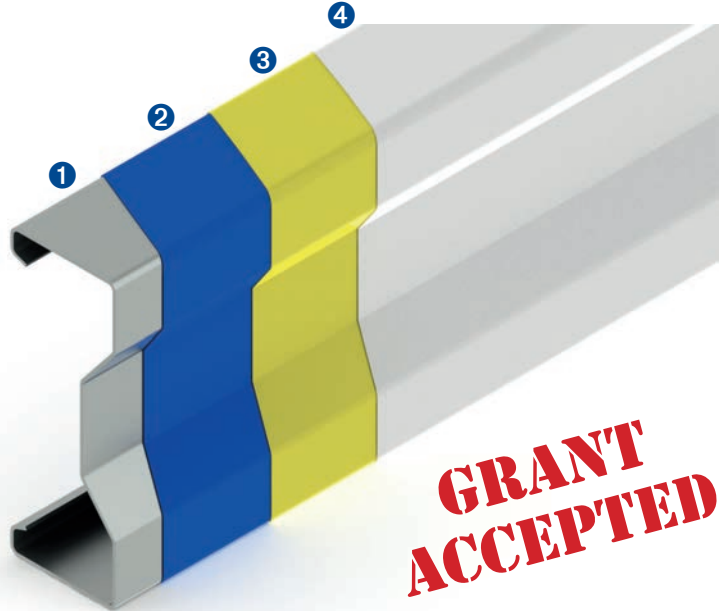

①+②

Basic Substrate: a galvanised crack-resistant steel with a coating weight of 275g/m², offering flexibility, corrosion resistance and durability.

③

A 15µm thick flexible primer specially designed to resist corrosion, applied on both sides.

④

A 20µm thick flexible chemical and corrosion resistant Polyester Resin finish (Chalk White Top Coat) applied on each side.



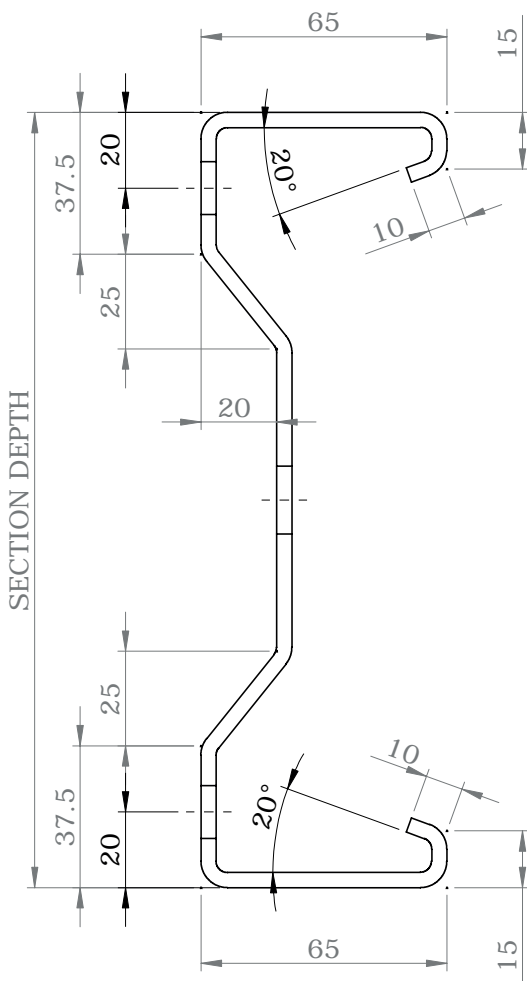
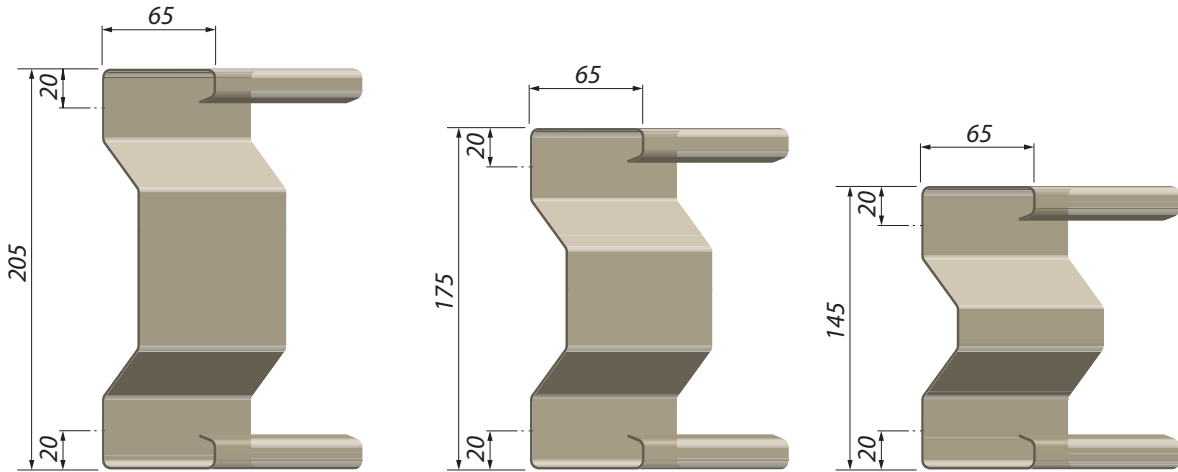

SECTION RANGE FOR PREPAINTED PROSIGMA+			
Thickness (mm)	Section Depth (mm)		
	145	175	205
1.5	DP-PSP-145/65/150	DP-PSP-175/65/150	DP-PSP-205/65/150
2.0	DP-PSP-145/65/200	DP-PSP-175/65/200	DP-PSP-205/65/200

Material specification:

Prepainted Purlins, Rails, Eaves Beams and Cee sections from the Duggan Profiles ProSigma+ range are manufactured from organically coated structural steel with the following characteristics:

Steel Name: S390
 Minimum yield strength: 390MPa
 Corrosion protection: Hot-dip zinc coating
 Coating designation: Z275
 Coating mass: 275g/m² (The minimum total coating mass both surfaces using triple spot test)

The painted finish to EN 10169:2010 is as follows:

Colour: Chalk White*

- 15µm thick flexible primer specially designed to resist corrosion, applied on both sides.
- 20µm thick flexible chemical and corrosion resistant Polyester Resin finish (Chalk White Top Coat) applied on both sides.

*The colour indicated is for information purposes only. Material samples are the only reliable indicator of colour and are available on request.

The ProSigma+ range from Duggan Profiles is a range of purlins and rails suitable for use in agricultural applications. It may be used with all types of conventional modern roof and wall cladding.

Design of the ProSigma+ profile has been in accordance with Eurocode 3, BS EN 1993-1 3:2006 and complemented by extensive physical testing. The result is an efficient range of sections which when used with appropriate anti sag systems combine to suit the widely varying conditions and loadings imposed by modern building techniques.

The material thickness is to EN 10143:2006 Continuously hot-dip coated steel sheet and strip. Tolerances on dimensions and shape.

Section properties:

Section properties have been calculated in accordance with Eurocode 3, BS EN 1993-1 3:2006. The top flange of the purlin must have adequate restraint provided by robust steel sheeting (or similar) fixed directly to the top flange.

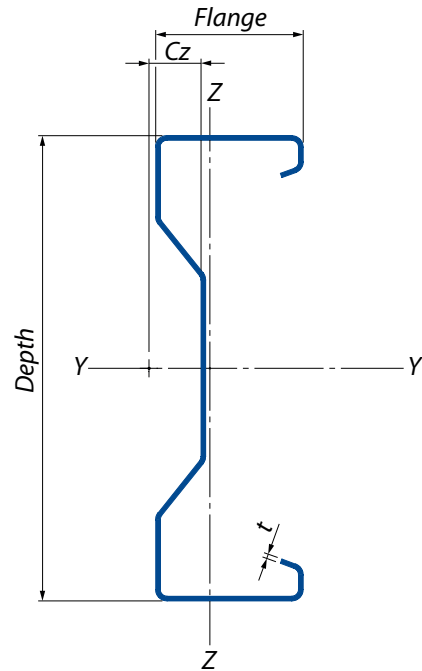

NOMINAL DIMENSIONS					SECTION PROPERTIES						
Section reference	Weight kg/m	Depth mm	Flange mm	Thickness mm	Area cm ²	I _{yy} cm ⁴	I _{zz} cm ⁴	i _y cm	i _z cm	C _z cm	M _y , R _k kNm
DP-PSP-145x65x1.5	3.71	145	65	1.5	473.09	153.97	24.62	5.70	2.28	23.77	7.50
DP-PSP-145x65x2.0	4.91	145	65	2.0	625.30	201.29	31.77	5.67	2.25	23.40	13.07
DP-PSP-175x65x1.5	4.06	175	65	1.5	516.89	239.33	24.68	6.80	2.19	23.45	9.66
DP-PSP-175x65x2.0	5.37	175	65	2.0	684.10	313.49	31.83	6.77	2.16	23.10	16.86
DP-PSP-205x65x1.5	4.40	205	65	1.5	560.69	347.95	24.73	7.88	2.10	23.18	11.99
DP-PSP-205x65x2.0	5.83	205	65	2.0	742.90	456.48	31.89	7.84	2.07	22.86	20.96



'SCI Assessed Quality Mark'. This mark testifies that the Steel Construction Institute (SCI) has independently verified the technical data above.

Figures and Comments given here are given for guidance purposes only. While care has been taken to ensure accuracy Duggan Profiles & Steel Service Centre Ltd. and its related companies do not accept liability for errors / or omissions. Customers should satisfy themselves of the suitability of the products supplied or manufactured by Duggan Profiles & Steel Service Centre Ltd. for the use intended.

SINGLE SPAN PURLINS - LOAD TABLES

The Span Tables below have been created in accordance with EN 1993-1-3 (Eurocode EC3) and calculated by the Steel Construction Institute (SCI).

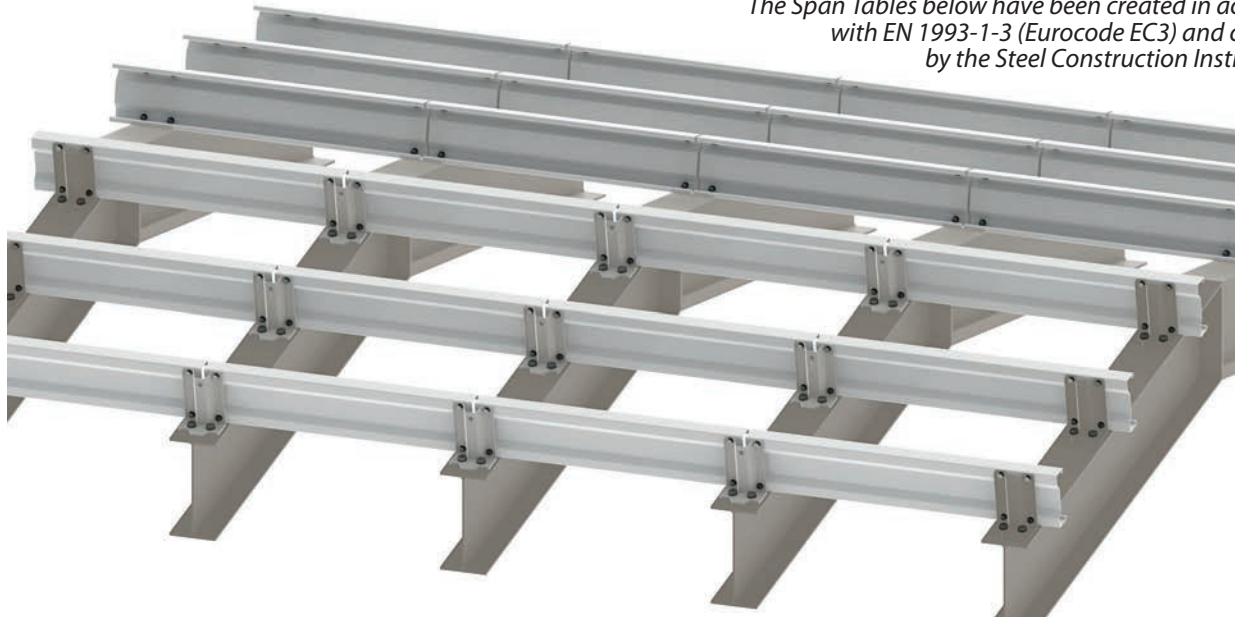

Note:

- Loads shown are based on lateral restraint being provided to the top flange of the purlin by the cladding. For purlin applications where no lateral restraint is offered by cladding please contact our technical department.
- The self weight of the section has not been deducted from the loads given below.

Span (m)	Section Type	Total Working U.D.L. (kN)	Working Loads					Deflection Span/180	Ultimate U.D.L. In kN/Span			
			Allowable loading in kN/m ²						Gravity Load	Uplift - metal cladding		
			Purlin centres in millimetres							0	1	2
1200	1400	1600	1800	2000	0	1	2					
4.8	145x65x1.5	8.34	1.45	1.24	1.09	0.97	0.87	8.36	12.51	7.42	10.94	12.51
	145x65x2.0	10.93	1.90	1.63	1.42	1.27	1.14	10.93	21.78	12.16	17.19	21.78
	175x65x1.5	10.74	1.86	1.60	1.40	1.24	1.12	11.16	16.11	8.56	13.02	16.11
	175x65x2.0	14.62	2.54	2.18	1.90	1.69	1.52	14.62	28.11	13.94	20.29	27.30
	205x65x1.5	13.33	2.31	1.98	1.74	1.54	1.39	16.22	19.99	9.43	14.85	19.85
	205x65x2.0	21.29	3.70	3.17	2.77	2.46	2.22	21.29	34.94	15.25	22.94	31.67

Span (m)	Section Type	Total Working U.D.L. (kN)	Working Loads					Deflection Span/180	Ultimate U.D.L. In kN/Span			
			Allowable loading in kN/m ²						Gravity Load	Uplift - metal cladding		
			Purlin centres in millimetres							0	1	2
1200	1400	1600	1800	2000	0	1	2					
6.1	145x65x1.5	5.18	0.71					5.18	9.84	5.23	7.25	9.64
	145x65x2.0	6.77	0.92	0.79	0.69			6.77	17.14	8.76	11.51	15.22
	175x65x1.5	6.91	0.94	0.81	0.71			6.91	12.67	5.98	8.51	11.59
	175x65x2.0	9.05	1.24	1.06	0.93	0.82	0.74	9.05	22.12	9.96	13.40	18.15
	205x65x1.5	10.05	1.37	1.18	1.03	0.91	0.82	10.05	15.73	6.52	9.56	13.35
	205x65x2.0	13.18	1.80	1.54	1.35	1.20	1.08	13.18	27.49	10.79	14.93	20.73



'SCI Assessed Quality Mark'. This mark testifies that the Steel Construction Institute (SCI) has independently verified the technical data above.

Figures and Comments given here are given for guidance purposes only. While care has been taken to ensure accuracy Duggan Profiles & Steel Service Centre Ltd. and its related companies do not accept liability for errors / or omissions. Customers should satisfy themselves of the suitability of the products supplied or manufactured by Duggan Profiles & Steel Service Centre Ltd. for the use intended.

Quality:

Corricolor® is a premium quality product manufactured from galvanised coil to European Standard EN 10147 : 1992. It consists of a steel substrate which is galvanised for additional protection. The outer surface is treated, primed and coated with Slate Grey, Juniper Green or Turf Brown polyester.

Internal Environment:

The inner surface is treated, primed and coated with a bright polyester finish. Corricolor® has a light coloured undercoat which gives a bright, airy atmosphere particularly important for good working conditions.

Tolerances:

All dimensions are subject to roll forming tolerances.

Stock:

Corricolor® is available in 0.50mm thickness cut to length.

Colour:

Corricolor® is available in standard colours, Slate Grey and Juniper Green.

Manufacture:

Corricolor® is manufactured by Duggan Profiles & Steel Service Centre Ltd., a Duggan Steel Group Company committed to total quality products.

With management experience in serving the farming and business communities extending over forty years, D.P. & S.S.C. is confident of its ability to serve your requirements no matter how specific they may be.

Storage & Handling:

Corricolor® must not be stored outside. Water ingress between sheets will have a negative effect on the performance of the sheet. Wrapping is only a temporary protection for transport purposes.

For advice on storage and handling please consult the leaflet enclosed in each bale of Corricolor®.

Distribution:

Corricolor® is available countrywide through our long established customer base of approved merchants, stockholders, manufacturers and erectors.

Should you have any trouble locating your nearest supplier please contact our office.

Accessories:

D.P. & S.S.C. provides a full range of complementary services and products for the sheeting range including cocktailing and curving facilities, gutters, trims, flashings, fittings and roof lights.

Guaranteed Irish:

Corricolor® is a guaranteed Irish product.

CORRICOLOR 14/3 PROFILES: (Not recommended for spaced roofing)

Please Note: Lap minimum recommendation for roofs is One and a Half Lap or Double Lap

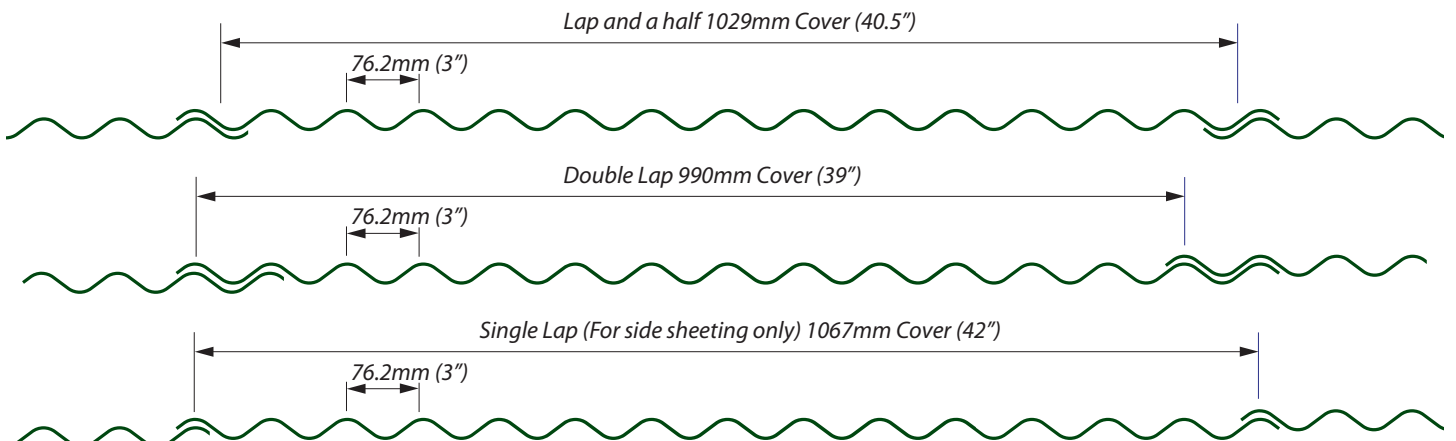

Quality:

Procolor® is a premium quality product manufactured from galvanised coil to European Standard EN 10147 : 1992. It consists of a steel substrate which is galvanised for additional protection. The outer surface is treated, primed and coated with Slate Grey, Juniper Green or Turf Brown polyester.

Internal Environment:

The inner surface is treated, primed and coated with a bright polyester finish. Procolor® has a light coloured undercoat which gives a bright, airy atmosphere particularly important for good working conditions.

Profile:

Procolor® is manufactured in a 32mm deep profile with a 200mm pitch in a 1000mm cover width, with mini-ribs. (Mini-Ribs can be omitted if specified at time of order).

Tolerances:

All dimensions are subject to roll forming tolerances.

Stock:

Procolor® is available in 0.50mm thickness cut to length in Roof and Reverse profiles.

Colour:

Procolor® is available in standard colours, Slate Grey and Juniper Green.

Manufacture:

Procolor® is manufactured by Duggan Profiles & Steel Service Centre Ltd., a Duggan Steel Group Company committed to total quality products.

With management experience in serving the farming and business communities extending over forty years, D.P. & S.S.C. is confident of its ability to serve your requirements no matter how specific they may be.

Storage & Handling:

Procolor® must not be stored outside. Water ingress between sheets will have a negative effect on the performance of the sheet. Wrapping is only a temporary protection for transport purposes.

For advice on storage and handling please consult the leaflet enclosed in each bale of Procolor®.

Distribution:

Procolor® is available countrywide through our long established customer base of approved merchants, stockholders, manufacturers and erectors.

Should you have any trouble locating your nearest supplier please contact our office.

Accessories:

D.P. & S.S.C. provides a full range of complementary services and products for their sheeting including clearlights, gutters, trims, flashings and up-stands.

Full crimping facilities are available for our 1000/32 Procolor®.

Guaranteed Irish:

Procolor® is a guaranteed Irish product.

PROCOLOR® 1000/32 PROFILE:

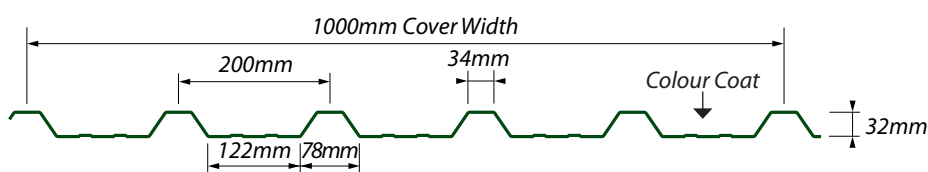

Quality:

Corrigalv® is a premium quality product manufactured to EN 10327:2004. It is galvanised for unbeatable long life and is surface treated to prevent oxidisation when in storage.

Corrigalv® is available in Z275 grammes per square metres in 0.55mm and in 0.70mm.

Stock:

Corrigalv is available in stock lengths 6', 7', 8', 9', 10', 11', 12' or cut to length.

Manufacture:

Corrigalv® is manufactured by Duggan Profiles & Steel Service Centre Ltd., a Duggan Steel Group company committed to total quality products. With management experience in serving the farming and business communities extending over forty years, D.P. & S.S.C. is confident of its ability to serve your requirements.

Distribution:

Corrigalv® is available countrywide through our long established customer base of approved merchants, stockholders, manufacturers and erectors. Should you have any trouble locating your nearest supplier please contact one of our offices.

Accessories:

D.P. & S.S.C. provides a full range of complementary services and products for the sheeting range including cocktailing and curving facilities, gutters, trims, flashings, fittings and roof lights.

Guaranteed Irish:

Corrigalv® is a guaranteed Irish product.

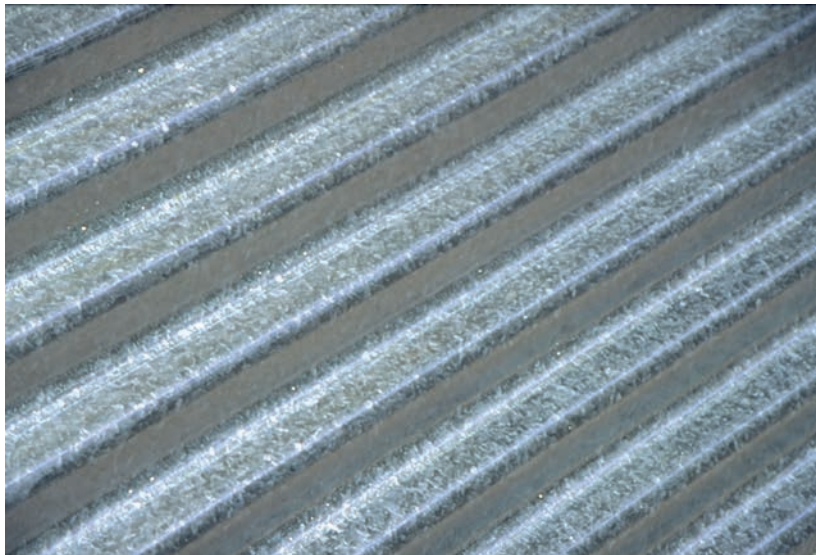

CORRIGALV® 10/3 PROFILE:

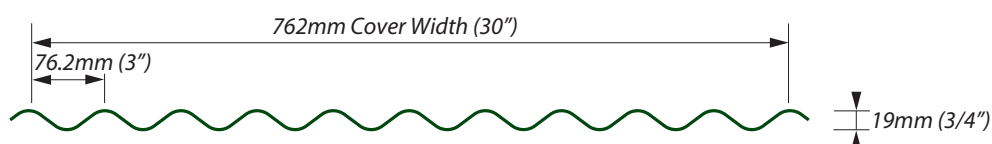

8/3 CORRUGATED PROFILE

Quality:

Duggan Profiles & Steel Service Centre Ltd. 8/3 GALV is a premium quality product manufactured to EN 10327:2004 and is surface treated to prevent oxidisation while in storage. 8/3 Galv is available in Z275 grammes per square metres in 0.50mm thickness.

Stock:

D.P. & S.S.C. 8/3 GALV is available in stock lengths 6', 7', 8', 9', 10', 11', 12' or specific lengths made to order.

Tolerances:

All dimensions are subject to roll forming tolerances.

Manufacture:

8/3 GALV is manufactured by Duggan Profiles & Steel Service Centre Ltd., a Duggan Steel Group company committed to total quality products.

With management experience in serving the farming and business communities extending over forty years, D.P. & S.S.C. is confident of its ability to serve your requirements.

Distribution:

D.P. & S.S.C. 8/3 GALV is available countrywide through our long established customer base of approved merchants, stockholders, manufacturers and erectors. Should you have any trouble locating your nearest supplier please contact one of our offices.

Economy:

D.P. & S.S.C. 8/3 GALV is the most economical form of galvanised roof cover available in Ireland today. It is suitable for general purpose use.

For specialised uses such as animal housing and /or grant aided farm building may we recommend our grant approved range of sheeting.

Accessories:

D.P. & S.S.C. provides a full range of complementary services and products for the sheeting range including cocktailing and curving facilities, gutters, trims, flashings, fittings and roof lights.

Guaranteed Irish:

8/3 Galv is a guaranteed Irish product.

8/3 GALV PROFILE:

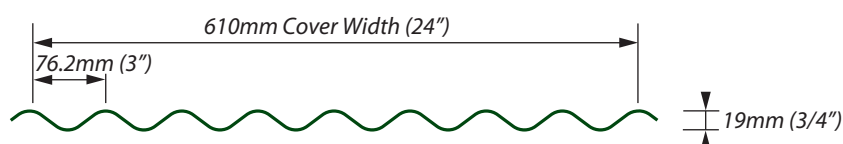

Box profile Insulated Steel Sheet with Aluminium Foil Backing Available in Standard Lengths ex Stock in Polyester Juniper Green or Slate Grey

ProTherm-40 is a trapezoidal foil faced insulated steel sheet for agricultural and low cost roof and wall applications.

The Foil faced insulated sheet is a through fixed roof and wall sheet, which can be used for all building applications, where the roof slope is 8° or more and vertical only on a wall. Buildings with no heat may need to be ventilated.

Standard stock lengths:

3.215m

4.800m

6.360m

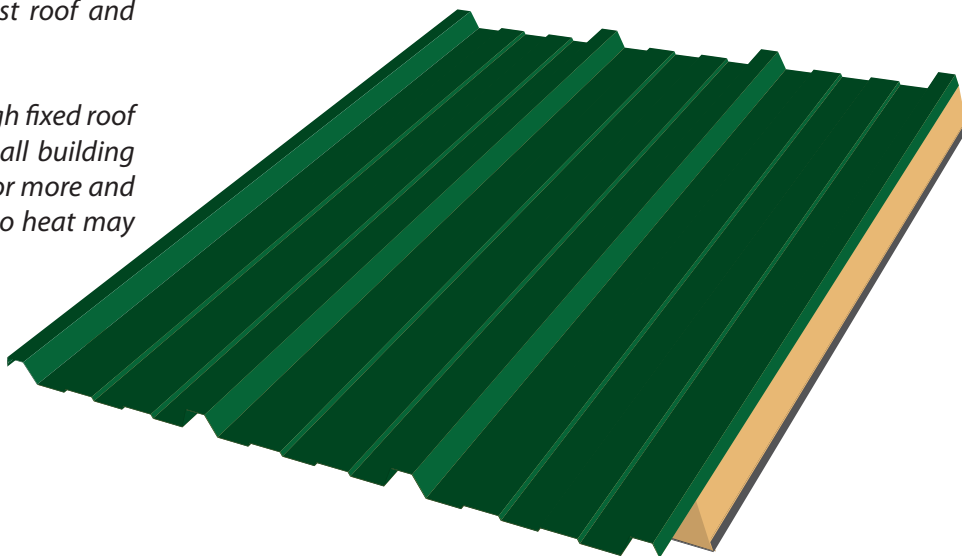

PANEL END CUT BACK

All panels are produced with a cut back of 100mm, opposite end flush cut.

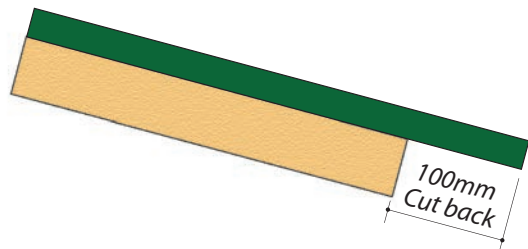

ENVIRONMENTAL

ProTherm-40 foil faced insulated sheet has a Green Guide A+ rating as per the BRE Global "The Green Guide To Specification", Green Guide 2008 ratings.

PERFORMANCE

Thermal Insulation

Core Thickness: 40mm

U value (W/m²K) 0.46

Fire:

The external face is Class 0 in accordance with the Building Regulations when tested to BS476: Parts 6: 1989 and Part 7: 1987. The external face is rated SAA when tested to BS476: Part 3: 1975. The internal foil facing has a Class 0 Surface Spread of Flame Rating.

Biological

ProTherm-40 foil faced insulated sheet is normally immune to attack from mould, fungi, mildew and vermin. No urea formaldehyde is used in the construction, and the sheets are not considered deleterious.

DIMENSIONS & WEIGHT

Core Depth: 40mm

Overall Thickness: 75mm

Weight kg/m² nominal 0.5/foil steel 6.7

PRODUCT TOLERANCES

Cut to Length -0.1% +0.1%

Liner Sheet Length -0.1% +0.1%

Cover Width -2mm +3mm

Thickness -2mm +2mm

End Square -3mm +3mm

Slight shade variations may occur in production batches.

QUALITY & DURABILITY

ProTherm-40 foil faced insulated sheets are manufactured from the highest quality materials, using state of the art production equipment to rigorous quality control standards, complying with ISO9001 standard, ensuring long term reliability and service life. The sheets have also been manufactured under Environmental Management System Certification ISO 14001:2004.

INSTALLATION INSTRUCTIONS

Side Lap

All external side laps to be weather sealed along the full length by an unbroken bead of 6mmx5mm thick butyl rubber sealant tape.

End Lap

When required all external end laps to be 100mm long, and weather sealed along the full width using two unbroken runs of 6mmx5mm thick butyl rubber sealant tape, first run located not more than 20mm upslope. End Laps to be tail stitched at each crown location 50mm upslope from end-lap.

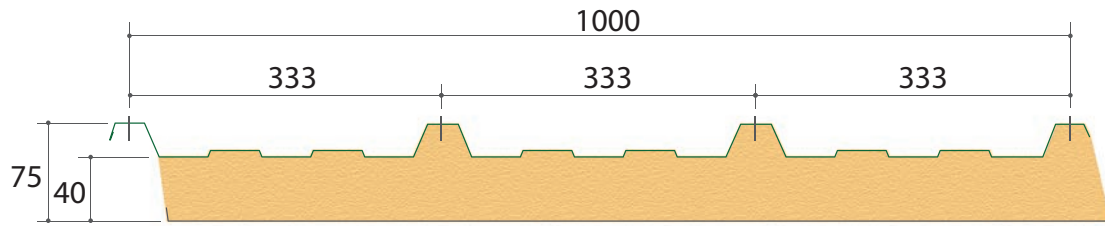

Fillers

Where flashings are fixed across the profile of the insulated panel, EPDM faced closed cell polyethylene foam fillers should be used to seal and close the profile. Seal the top, bottom and sides of each profiled filler with non-curing gun-grade sealant.

FASTENERS

Primary

All primary fasteners must be the high threaded type manufactured from carbon steel, anti-corrosion coated, and fitted with a 19mm diameter bonded stainless steel washer. All fasteners to be located through every crown of the profile i.e. three fixings per panel per purlin.

Secondary

Side laps and flashings to be stitched at 450mm centres

(maximum) with carbon steel stitching screws, complete with 14mm diameter bonded stainless steel washers.

PURLINS

Typical purlin centres should not exceed 1500mm centres for general locations.

In some locations closer centres may be required. ProTherm-40 foil faced insulated sheets are suitable to be fixed to cold rolled, hot rolled and timber purlins. However when fixing to treated timber purlins an EPDM must be used to prevent any reaction between the treatment and the foil liner of the sheets.

ROOFLIGHTS

Rooflights can be used as part of the Protherm-40 sheet system and must be installed in strict accordance with manufacturer's instructions.

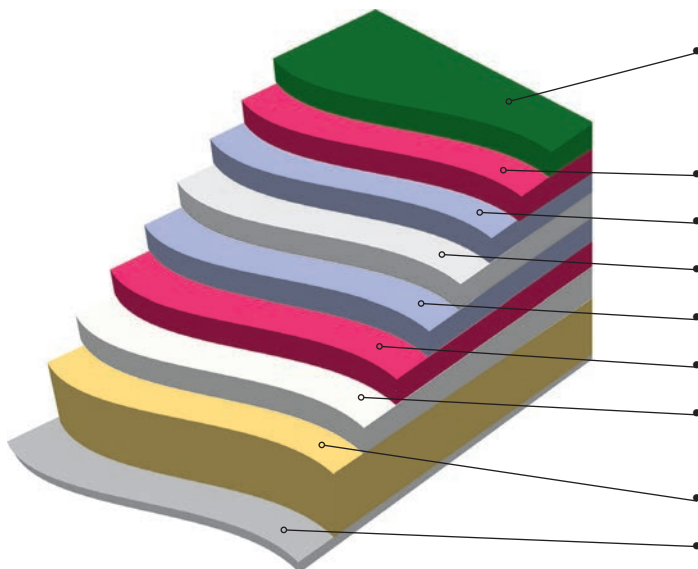

High Performance coating applied to the weather side of the steel sheet (Juniper Green or Slate Grey)

Primer

Galv

Steel substrate

Galv

Primer

Light Grey polyester coating on reverse side of steel sheet

40mm Polyisocyanurate (PIR) insulation core

50micron Internal Liner Aluminium Foil

MATERIALS:

Steel Substrate

Arcelor Granite Standard S220GD+ZA hot-dip zinc/aluminium Galfan coated steel to BS EN10214: 1992. Standard external sheet thickness nominal 0.5mm, standard internal foil thickness 50micron.

Foil Liner: Material aluminium foil with protective lacquer, alloy EN AW 1200 / Al 99,0 to DIN EN 573-3, Standard internal foil thickness 50micron.

Coatings - External Weather Sheet

Arcelor Granite Standard High performance coating applied to the weather side of the panel. Designed to achieve high

levels of durability and colour stability, is highly resistant to damage in transit and on-site. Colours available Juniper Green & Slate Grey.

Reverse side of sheet coated with a light grey polyester coating.

Coating - Internal Liner Foil

Exposed internal face of foil coated with a protective lacquer – $8.0 \pm 1.7 \text{ g/m}^2$. Reverse side of foil coated with an adhesive lacquer – $1.7 \pm 0.6 \text{ g/m}^2$.

INSULATION CORE

Polyisocyanurate (PIR): EcoSafe PIR formulation. Receiving BREEAM Credit (Pollution 4: Insulant GWP) 2006 credit.

NONDRIP™ ROOFING: THE SOLUTION TO CONTROL CONDENSATION



For Terms & Conditions:
See website at www.steel.ie

**GRANT
ACCEPTED**



In non-insulated metal buildings, cold air outside + warm air and humidity inside create condensation on the under side of the steel sheeting resulting in droplets of water dripping down.

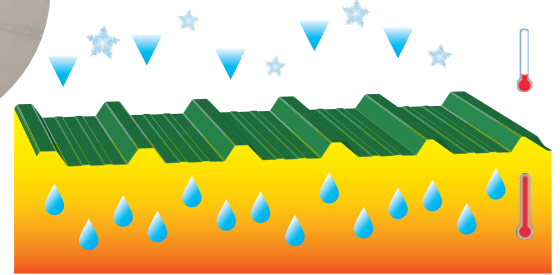

NonDrip™ is a nonwoven fibre material specially designed to control condensation in non-insulated metal buildings, based on ventilation.

The NonDrip™ membrane can control condensation in an environment where the condensation appears cyclically. The fibre - microsphere structure is capable of absorbing over 900 grams of condensation water per square meter (Depending on the slope of the roof).

In order to work properly, the NonDrip™ Membrane needs to get dry in between cycles. For that reason adequate ventilation inside a building is necessary.

NonDrip™ can now be applied on our range of 14/3 corrugated or 1000/32 box profile coated steel.

Grant Accepted sheeting supplied with a 15-year guarantee will not be affected when NonDrip™ is applied. NonDrip™ also carries a 15-year guarantee when used in compliance with the manufacturer's instructions.

The Department of Agriculture, Fisheries and Food has confirmed that NonDrip™ may be applied to our range of accepted cladding sheets for use in grant-aided buildings.

Storage conditions:

NonDrip™ coated sheets must be stored flat under conditions that protect them from humidity (e.g. Suitably wrapped under a weather proof sheet or in a covered warehouse).

Installation precautions:

To prevent damage to the NonDrip™ coating, avoid rubbing the sheets together and / or against the roof structure.

If the sheets are to be fixed on a timber structure, a strip of roofing felt should be placed between the sheet and the structure.

Ensure that the bottom of the sheet is capable of draining condensed water into a gutter. The metal sheet that is draining condensed water into the gutter should be installed in such a way that the NonDrip™ is clearly overhanging into the gutter.

Application conditions and restrictions:

To ensure proper functioning, NonDrip™ should not be used in climate zones or in buildings where relative humidity approaches saturation for extended periods.

In certain environments in particular, the function of NonDrip™ can be affected, e.g.: In buildings with humidity production, buildings with poor ventilation, buildings with presence of corrosive gasses or rooms with a dusty atmosphere, etc.

It is the designer/specifier's responsibility to ensure overall compliance with the Building Regulations.

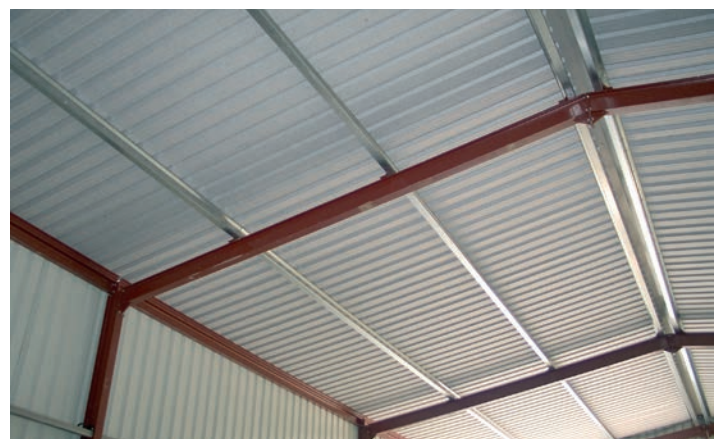

**ROLL-FORMED GUTTER,
DOWNPIPE SYSTEM AND
ACCESSORIES**

*100mm Bevel Gutter and downpipe system
now available in Galv and Prepainted Steel
(Juniper Green and Slate Grey)
to match our range of profiled steel sheets.
Standard lengths in stock and bespoke lengths
also available on request.
Easy installation with our 6mm galvanised brackets.
Self-hanging option available (ie. no brackets required)*



Galvanised support brackets

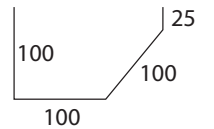
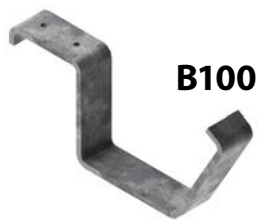
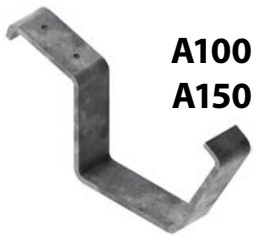

100mm Bevel Gutter
x 4.876m x 1mm

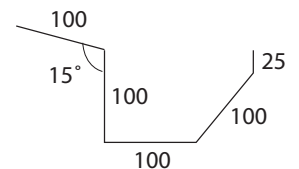

100mm Self-hanging
Bevel Gutter
x 4.876m x 1mm

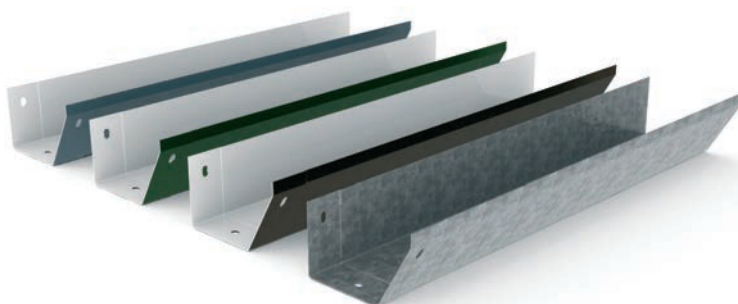

STANDARD FLASHINGS (Available from stock in Slate Grey, Juniper Green, Turf Brown and Galv. For Non-Standard Flashings, please contact our Sales Office)

Ridge Cap x 3m
200x200mm Juniper Green

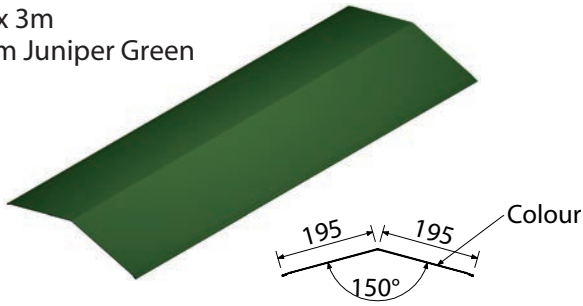

Barge Board x 3m
115x135mm Juniper Green

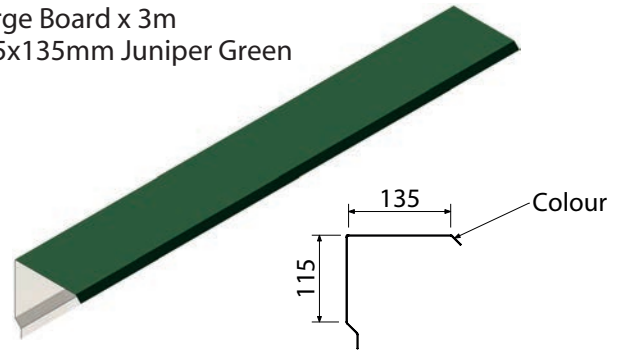

Ridge Cap x 3m
300x300mm Juniper Green

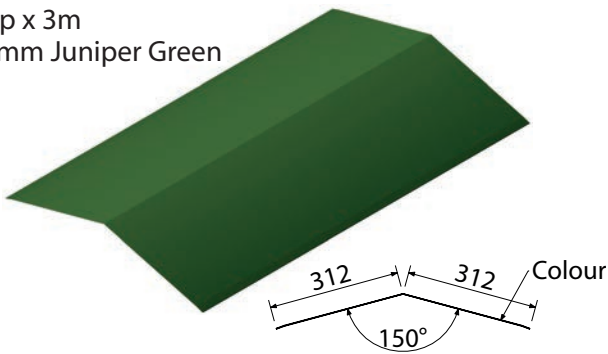

Corner Flashing x 3m
150x150mm Juniper Green

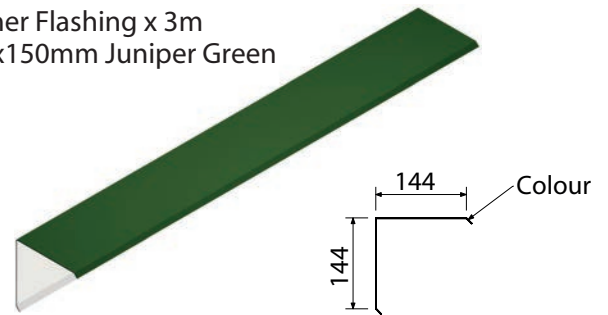

Drip Flashing x 3m
90x40x30mm Juniper Green

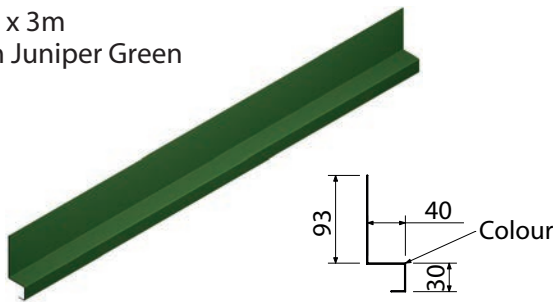

Barge Board x 3m
115x250mm Juniper Green

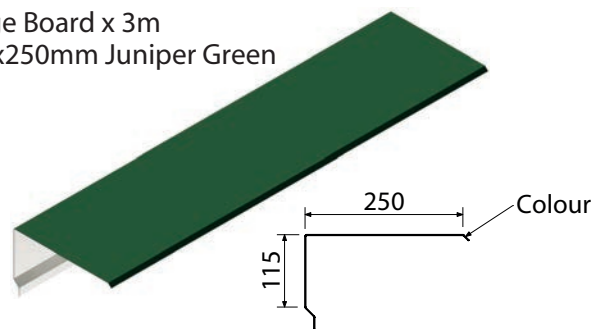

Apron Flashing x 3m
250x150mm Juniper Green

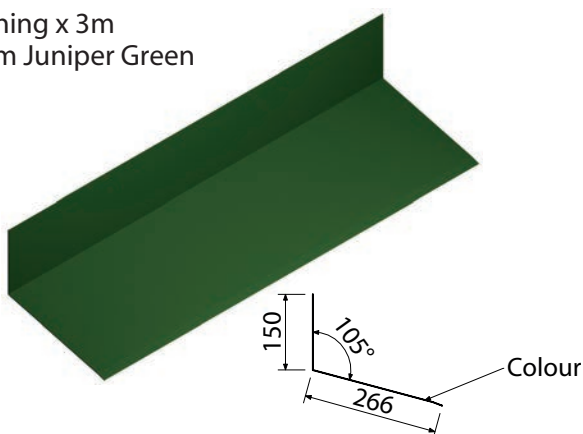

Door Hood Juniper Green x 3m
75x150x210mm

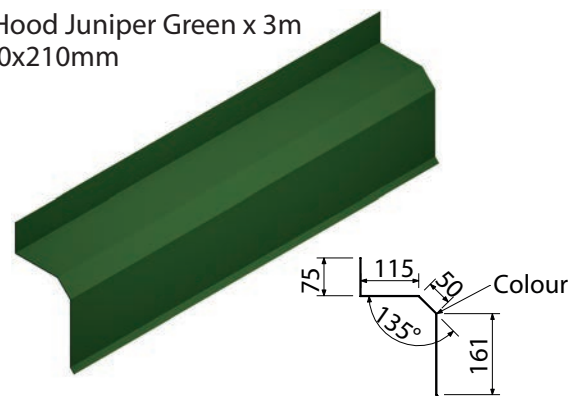

Mono Ridge x 3m
250x150mm Juniper Green

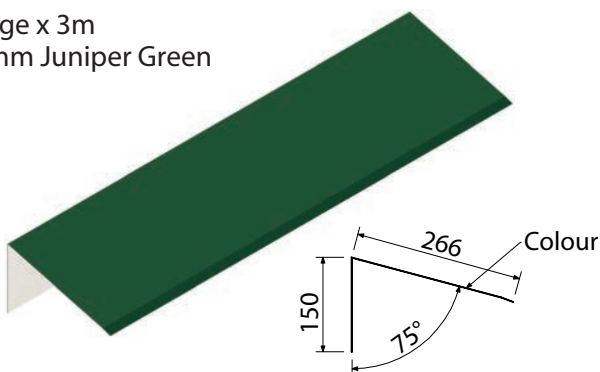

The image shows three overlapping order forms from Duggan Steel. The top form is for 'Agri Gutters & Accessories', the middle for 'Agri Flashings & Trims', and the bottom for 'HiLine Gutters'. Each form contains a header with the company name and contact information, followed by a form body with various sections for product selection, material options, and technical details. A 'TYPICAL SECTION' diagram is visible on the bottom form, showing a cross-section of a gutter with a girth, with dimensions like 30, 35, 100, and 165 (Standard), 125 (Mini), and 80 (Micro) indicated.

Request our Orderforms:

To facilitate order processing, electronic or paper orderforms are available from our Sales Office.

Dublin Road,
 Kilkenny - Ireland
 Tel.: +353-56-7722485
 Fax: +353-56-7763411
 E-mail: salesdp@steel.ie
 www.steel.ie



Do you have the most up to date information?

The information in this brochure is current at time of publication but subject to change due to product updates, technical advances and the passage of time. Our website provides the most comprehensive, authoritative and up to date source of information on all aspects of the business of the Duggan Steel Group. Check www.steel.ie regularly to ensure you are up to date.



For more information please visit our website

Dublin Road,
Kilkenny - Ireland
Tel.: +353-56-7722485
Fax: +353-56-7763411
E-mail: salesdp@steel.ie
www.steel.ie

PRO CLAD®

PRO UNER®

PRO COLOR®

PRO DECK®

PRO PURLIN®

PRO LIGHT®

PRO FARM®

PRO AIR®

CORRI FARM®

CORRI GALV®

AGRI PURLIN®

AGRI LIGHT®

PRO THERM-40

PRO SIGMA+®

DPSSC April 2015
© copyright Duggan Steel Group Ltd. 2015

www.steel.ie



Please Note: All reasonable care has been taken in the compilation of the information contained within this publication, but Duggan Steel Group Ltd. and its related companies do not accept responsibility for errors or for information which is found to be misleading. Suggestions for, or descriptions of the end use or application of products or methods of working are for information only and Duggan Steel Group Ltd. and its related companies accept no liability in respect thereof. It is the customer's responsibility to ensure that the product is fit for its intended purpose and that the actual conditions of use are suitable. It is also the customer's responsibility to ensure overall compliance with the current Health & Safety and Building Regulations. Dimensions are for illustration purposes only and subject to change. Duggan Steel Group pursues a policy of continuous product development and reserves the right to amend specifications without prior notice. Please refer to our website www.steel.ie for the most up to date information.