

### EAVES BEAM SECTION OPTIONS (GALVANISED)

Product Code	SECTION DEPTH (MM)	THICKNESS (MM)	ANGLE	FINISH
DP-EBG180/200/00	180	2.0	0 - 30°	GALV
DP-EBG210/200/00	210	2.0	0 - 30°	GALV

### EAVES BEAM SECTION OPTIONS (PREPAINTED)

Product Code	SECTION DEPTH (MM)	THICKNESS (MM)	ANGLE	FINISH
DP-PEB180/200/00	180	2.0	0 - 30°	PREPAINTED
DP-PEB210/200/00	210	2.0	0 - 30°	PREPAINTED

**NOTES:**

THE LAST 2 DIGITS OF THE PRODUCT CODE DENOTE THE ANGLE. ALL THE CODES ABOVE SPECIFY AN ANGLE OF ZERO DEGREES, TO SPECIFY AN ANGLE GREATER THAN ZERO THE LAST 2 DIGITS SHOULD BE REPLACED WITH THE REQUIRED ANGLE. EXAMPLE: DP-EBG180/200/06 DENOTES A GALVANISED EAVES BEAM OF 180 DEPTH WITH AN ANGLE OF 6 DEGREES.

TOLERANCES (UNO)			ALL DIMENSIONS IN MM	
DRAWN	SG	DATE	GRADE	
APPV'D		28/05/2009	THICKNESS	
MFG			QUANTITY	

TITLE: SIGMA EAVES BEAM PROFILE

CUSTOMER: DUGGAN PROFILES  
PART NO.



DUGGAN PROFILES & STEEL SERVICE CENTRE Ltd.

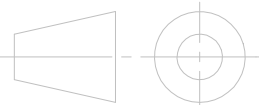

DWG NO. SIGMA\_EAVESBEAM\_PROFILE  
Rev

SCALE:1:20

1

2

3

4

5

6

A

A

B

B

C

C

D

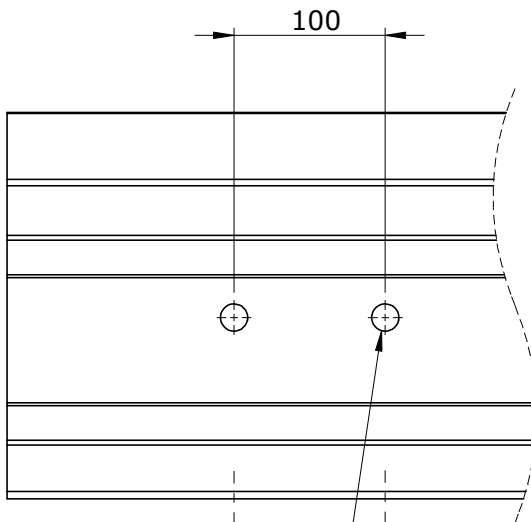
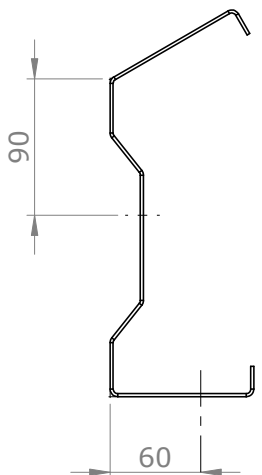

EAVES BEAM CLEAT HOLES - 4 X 18MM

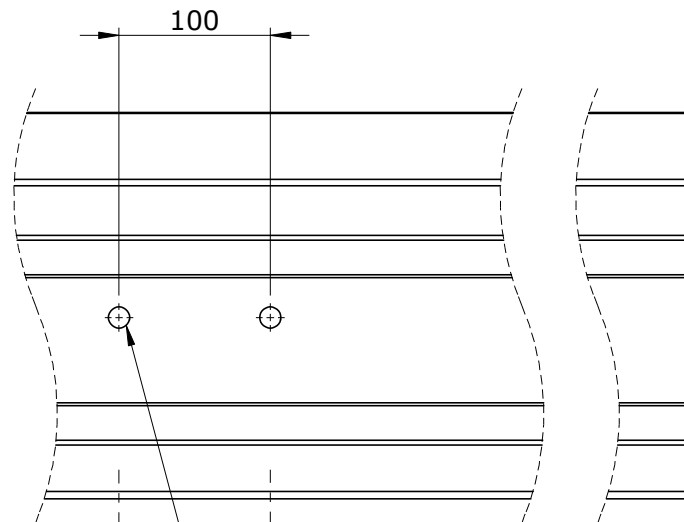

EAVES STRUT CLEAT HOLES - 4 X 14MM

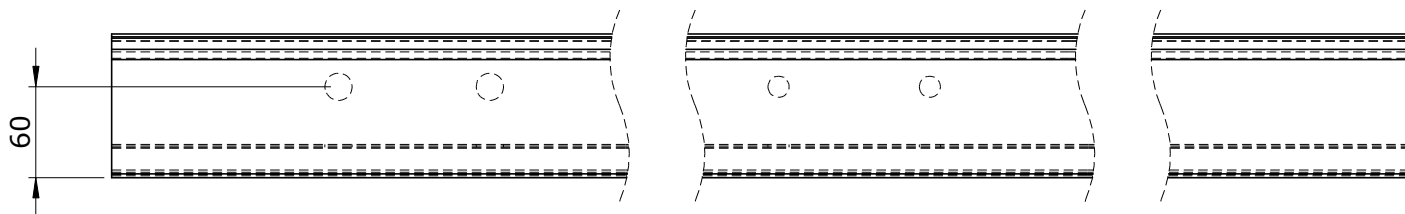

TOLERANCES (UNO)

ALL DIMENSIONS IN MM

TITLE: SIGMA EAVESBEAM PUNCHING

DRAWN	SG	DATE	28/05/2009
APPV'D			
MFG			

MATERIAL:	
GRADE	
THICKNESS	
QUANTITY	

CUSTOMER	DUGGAN PROFILES	PART NO.	
----------	-----------------	----------	--



DWG NO. SIGMA\_EAVESBEAM\_PUNCHING

Rev

SCALE:1:5

1

2